

**APPETIT®**

*Engelbrechts*

---

UNIVERSAL TABLES  
DESIGN MORTEN ENGELBRECHT

---

PRODUCTION  
ENGELBRECHTS



---

Appetit is an ordinary table with quite extraordinary potential. Four adjustable legs of polished aluminium and chrome. A lightweight blockboard of a suitable size, with rounded corners and bushings for the legs. And a choice of colours and surfaces can match any surrounding or occasion. Appetit is born to eat, learn and work with, like a condition that makes you yearn for more.

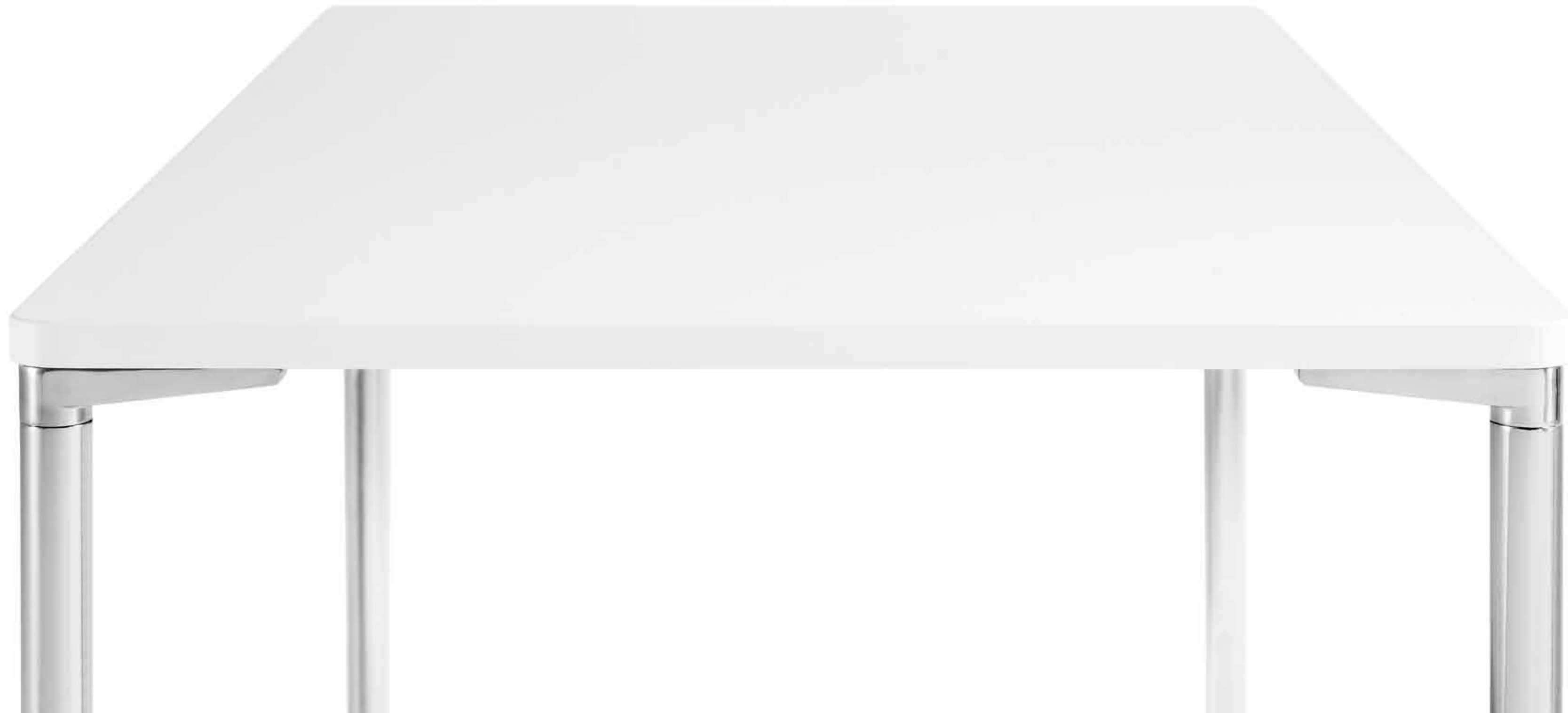



Appetit comes in any size and shape to suit the occasion, with white, grey or black laminate as well as range of veneers.





Height-adjustable non-slip studs secure safe grounding or come with built-in wheels for easy transport.



With docked bushings, the legs are mounted in minutes. Magnetic brackets link the tables without the use of tools.



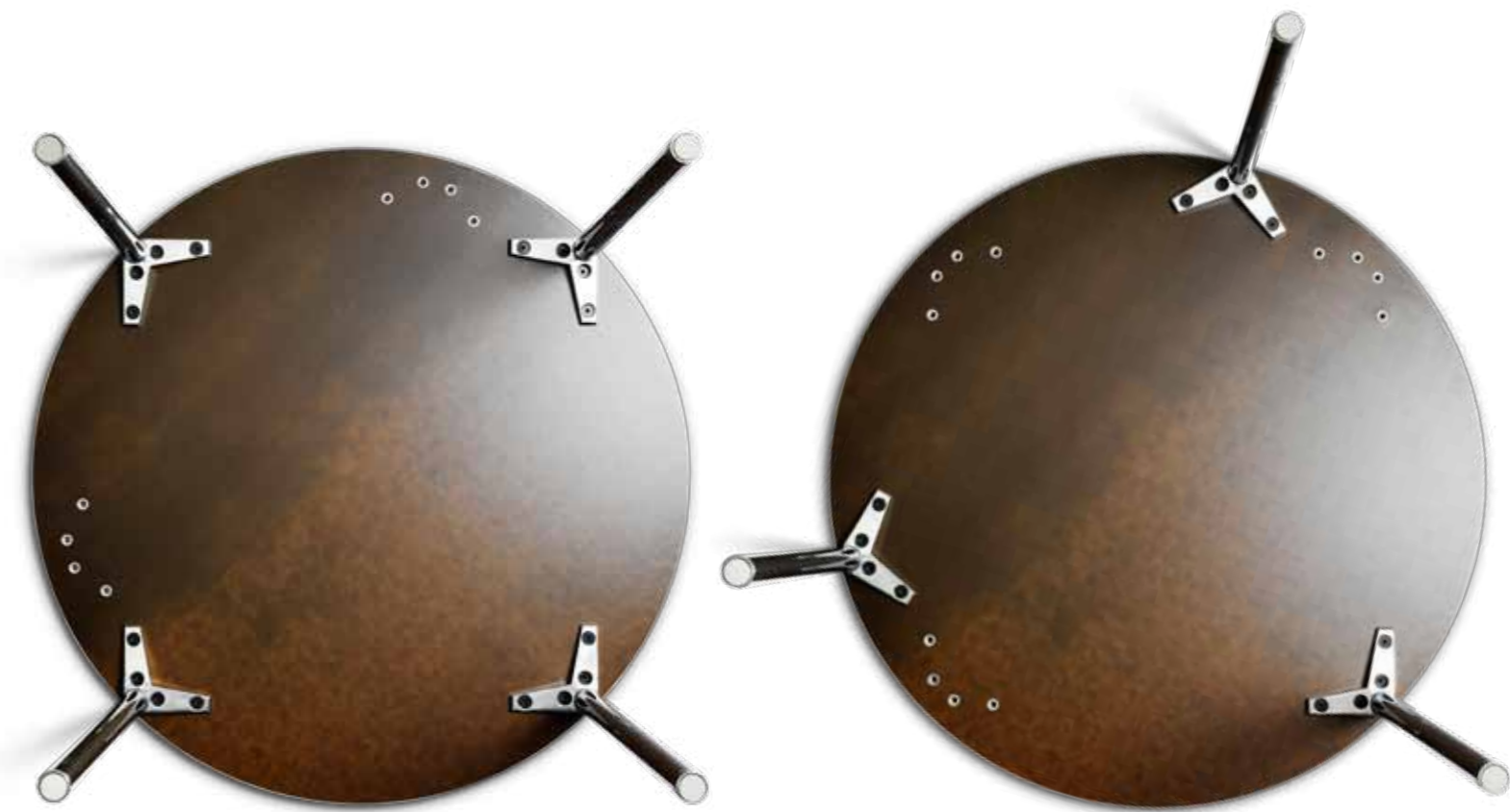



Suspension brackets for Chairik chairs are extra.



A self-supporting blockboard on double wing shanks ensures stability, and round corners leave no bruises.

DESIGNER  
MORTEN ENGELBRECHT

THE ART OF MAKING  
IT LOOK SO EASY

Morten Engelbrecht has lived and breathed furniture since he left school. First behind the counter, and since 1989, as manufacturer in his own right. With Appetit, he can add the title of Designer to his business card.

**APPETIT®  
UNIVERSAL TABLES**

All tabletops come with surfaces in white, grey or black laminate with matching ABS edges.

On request, a range of different veneers is available, too.

WHITE

GREY

BLACK



**So the manufacturer thinks of himself as a designer now?**

Yes and no. A light and flexible table system has been on the wish list for some time now and quite a few attempts have been made over the years. It's very much a matter of choosing against the excessive, and it's no coincidence that the result feels a bit minimalistic.

**So what's the trick?**

We have been very meticulous with the tools, and I'm really proud of the quality and finish that we ended up with. Take the rounded corners; they enable us to glue on the edges in one continuous process. This design characteristic becomes a double asset as it prevents bruising at close contact.

**What else did you learn?**

I learned how easy it is to pass judgement on the work of others. I must say though, I could nearly walk on water when it was all over. What we have is a versatile table that stands up to almost anything you put next to it.

**Will there be more?**

Perhaps, but I won't promise anything. Our business thrives on the fact that we are steadily in motion. We are constantly on the lookout for the best solution to a given problem. Some solutions come from ourselves, others are resolved externally. It is also not necessarily harmful to the dialogue with other designers now that I've been over the fence myself.

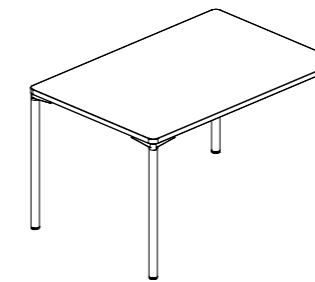

W 60 x L 120 x H 72 cm  
W 70 x L 120 x H 72 cm  
W 80 x L 120 x H 72 cm

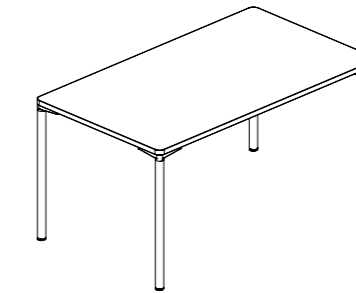

W 60 x L 140 x H 72 cm  
W 70 x L 140 x H 72 cm  
W 80 x L 140 x H 72 cm

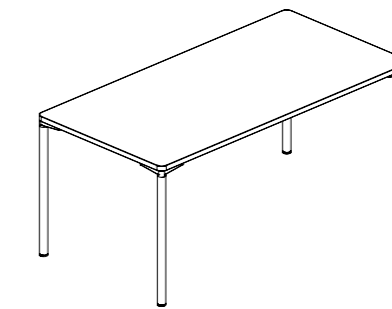

W 60 x L 160 x H 72 cm  
W 70 x L 160 x H 72 cm  
W 80 x L 160 x H 72 cm

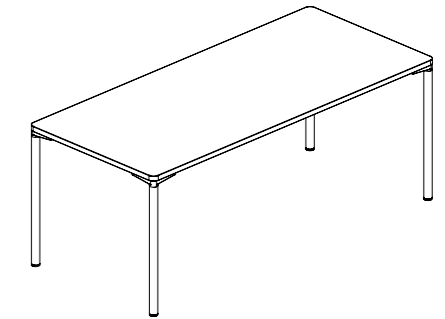

W 60 x L 180 x H 72 cm  
W 70 x L 180 x H 72 cm  
W 80 x L 180 x H 72 cm

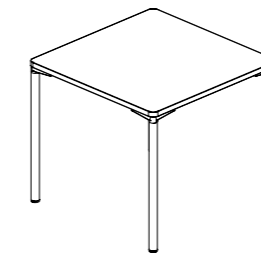

W 80 x L 80 x H 72 cm

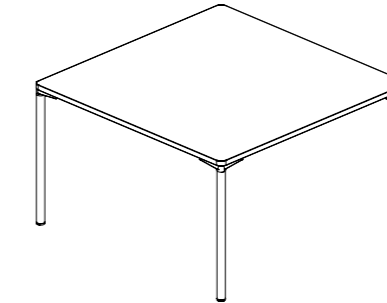

W 120 x L 120 x H 72 cm

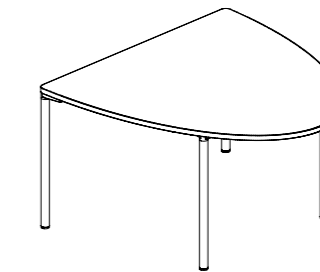

½ ø 120 x H 72 cm

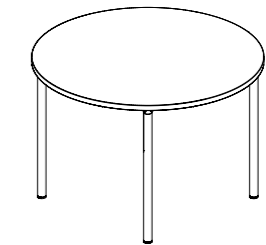

ø 105 x H 72 cm

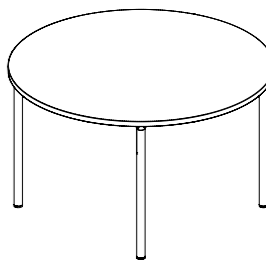

ø 120 x H 72 cm

# Engelbrechts

---

ENGELBRECHTS.COM

---

ENGELBRECHTS  
SKINDERGADE 38  
DK 1159 COPENHAGEN K  
T +45 3391 9896  
F +45 3391 9197