

PLASMA

Engelbrechts

TABLES & CHAIRS
DESIGN ERIK MAGNUSSEN

PRODUCTION
ENGELBRECHTS



Plasma is injection-moulded comfort for indoors and outdoors. Durability and weight-loss systematized with a loving bow to the toy construction set and an unusual textural effect in spite of the material. Moulded in glass-reinforced nylon, every piece serves its purpose and leaves the choice of colour to the user. With ten colours and four parts there are 10,000 variations on the theme.









Back-piece, seat with front-legs plus
two aluminium tubes – and hey presto!
Plasma receives the world. Add armrests
in matching colours or suitable contrast.



No pressure on the spine, not even when you stretch your legs and slide forward in the seat. A light rill-pattern prevents you from slipping over the edge.



Construction and static are hidden in the shape and the weight is less than 3 kilos. All parts can be shredded and recycled.







The Plasma table comes with a circular or square top in several materials and sizes. The foot is cast in aluminium.





There is plenty of room for the travelling eye in Erik Magnussen's workroom overlooking the Sound, just north of Copenhagen. A simple serenity makes time stand almost still. No matter where you fix your eyes, you recognise objects and furniture – and fall into reveries.



What does a potter and graphic designer know about furniture?

Nothing at all. I've never known anything about anything I did. But everyone knows about sitting, so I go on about it in my usual manner: Moving from the outside in, making things as easy as possible, dealing with as many obstacles as I can on the way. I'm a generalist, not a specialist. It gets much too complicated today if you stretch as far as I have allowed myself to. Fortunately, you meet clever people everywhere with the most amazing skills. With a bit of luck, two and two can make much more than five. All my life I've been at sea. Out there you learn that things must be durable, do the job without getting in the way, not weigh too much and stuff like that.

Have you got a working method?

It's probably best explained by the chair you're sitting in. If it's going to make sense to compete with people like Arne Jacobsen, your chair must present something new. Be it in terms of comfort or strength or workability. When you've gone over the lot, you can start arguing with yourself if there is any sense in crowding the world with yet another product.

What sense does Plasma make?

The assignment prescribed a plastic chair that was recyclable and would not weigh a ton. I started out in full scale with plaster and chicken wire over electric pipes, but the shape is mostly dictated by material and function. If you've worked a lot with plastic, it seems natural to put demands on the tactility. I wanted to get to the point where it feels like sitting down in a chair with a woven seat. With the growing colour scale, came the idea that the user himself should lend a hand to the design.

Can a material promote an expression?

Of course, but the opposite can also be the case. No matter whether you're toying with furniture or items for everyday use, they have a tactile dimension. You really have to have a feel for the material before you start out. At least, that's how it is with me.



**PLASMA
CHAIRS**

811 / without armrests

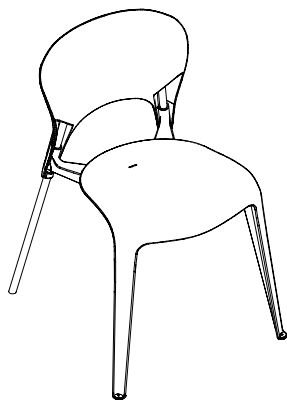

H 77 x SH 46 x D 55 x W 49 cm

**PLASMA
SQUARE TABLES**

Table top in laminate

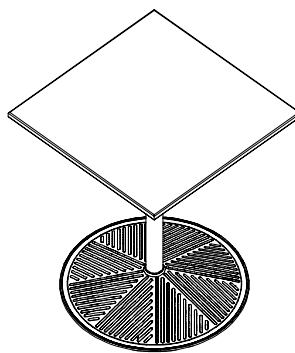

820 / 60 x 60 cm

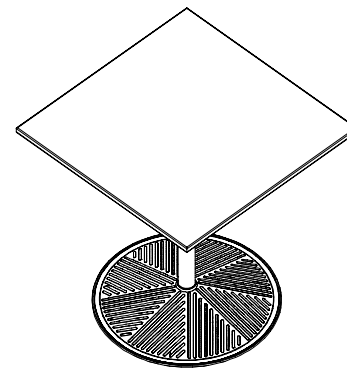

821 / 70 x 70 cm

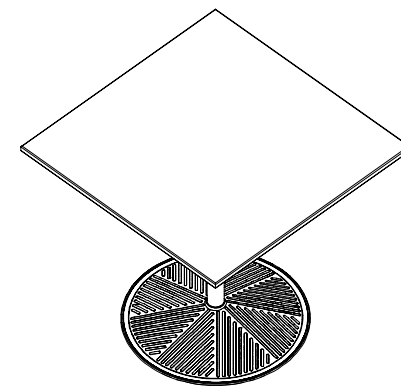

822 / 80 x 80 cm

**PLASMA
CHAIRS**

812 / with armrests (H 68,5 cm)

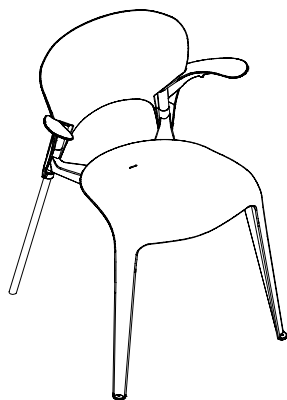

H 77 x SH 46 x D 55 x W 54 cm

**PLASMA
ROUND TABLES**

Table top in laminate / polished aluminium /
raw aluminium

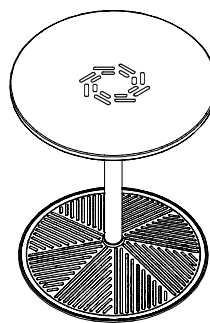

823 / Ø 60 cm

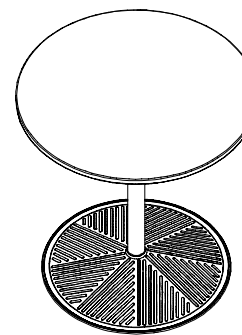

824 / Ø 70 cm

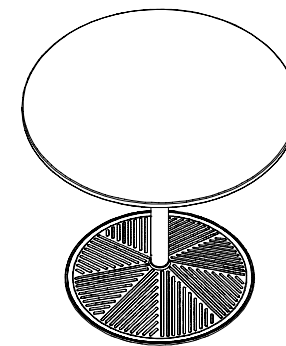

825 / Ø 80 cm



With ten colours and four parts the dedicated fan has 10,000 designs to choose between.

COLOURS AND MATERIALS

PLASTIC
BLACK

PLASTIC
LIME

PLASTIC
GREEN

PLASTIC
ORANGE

PLASTIC
RED

PLASTIC
LIGHT BLUE

PLASTIC
TURQUOISE

PLASTIC
BEIGE

PLASTIC
WHITE

PLASTIC
SAND

Engelbrechts

ENGELBRECHTS.COM

ENGELBRECHTS
SKINDERGADE 38
DK 1159 COPENHAGEN K
T +45 3391 9896
F +45 3391 9197